

SEA CRUIZE

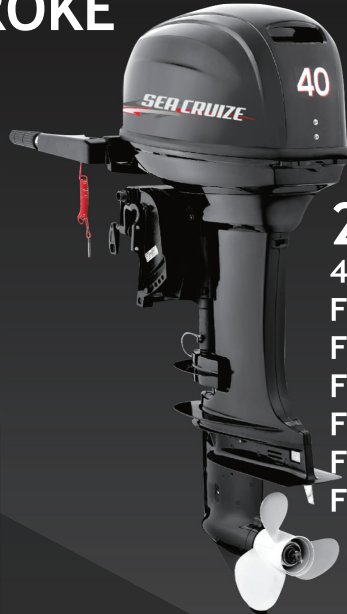

2-STROKE

60HP
FHL
FFEL
FFEL-T



2-STROKE

40HP
FHS
FHL
FFES
FFEL
FFES-T
FFEL-T



2-STROKE

30HP
FHS
FHL
FFES
FFEL



2-STROKE

15HP
FHS



2-STROKE

9.8HP
FHS



2-STROKE

5HP
FHS

ULTRA MARINE CO.,LTD

บริษัท อุลตรามารีน จำกัด

โทร. 097-154-2050, 02-235-5411

WWW.ULTRAMARINEBOAT.COM

Email : ultramarineboat@hotmail.com

Distributor/ตัวแทนจำหน่าย :

SEA CRUIZE

Model	5HP	9.8HP	15HP	30HP	40HP	60HP
Max. output	3.7 KW	7.2 KW	11 KW	22 KW	29.4 KW	44.1 KW
Recommended Max RPM	4500-5500	4500-5500	4500-5500	4500-5500	4500-5500	4500-5500
Stroke	2	2	2	2	2	2
Cylinder	1	2	2	2	2	3
Displacement (cc)	102	169	246	496	703	849
Bore X Stroke	55x43	50x43	56x50	72x61	80x70	72x69.5
Size (mm)	700x310x1010 (S) 700x310x1137 (L)	793x320x996 (S) 793x320x1123(L)	873x332x1040(S) 873x332x1167(L)	843x399x1146(S) 843x399x1273(L)	1073x402x1218(S) 1073x402x1345(L)	1197x364x1479 (L)
Weight	S:20Kg / L:21 Kg	S:26Kg / L:27Kg	S:36Kg / L:38Kg	S:53Kg / L:55Kg	S:72Kg / L:74Kg	L:102Kg
Gear Ratio	28:13 (2.15)	27:13 (2.08)	27:13 (2.08)	27:13 (2.08)	26:13 (2.00)	28:12 (2.33)
Gear Shift Position	F-N-R	F-N-R	F-N-R	F-N-R	F-N-R	F-N-R
Ignition System	CDI	TCI	CDI	CDI	CDI	CDI
Cooling System	Water Cooling	Water Cooling	Water Cooling	Water Cooling	Water Cooling	Water Cooling
Starting System	Manual	Manual	Manual	Manual&Electric Start	Manual&Electric Start	Manual&Electric Start
Control System	Tiller Control	Tiller Control	Tiller Control	Tiller&Remote Control	Tiller&Remote Control	Tiller&Remote Control
Capacity of Fuel Tank (L)	2.5L	12L	24L	24L	24L	24L

Company Strength



CNC Workshop



Assembling Workshop

High-Tec manufacturing equipment



Worldwide supply chain



ULTRA MARINE CO.,LTD

บริษัท อุลตรามารีน จำกัด

โทร. 097-154-2050, 02-235-5411

WWW.ULTRAMARINEBOAT.COM

Email : ultramarineboat@hotmail.com

Distributor/ตัวแทนจำหน่าย :